

KRAGSTA

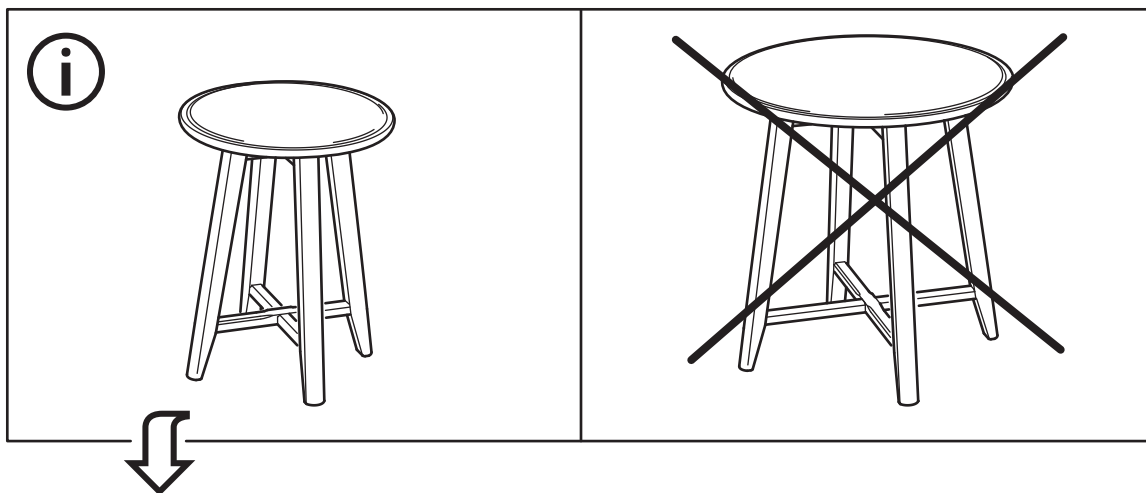

Design and Quality
IKEA of Sweden



English

WARNING – Delicate table – Do not sit on the product.
 WARNING – Delicate table – Do not place heavy objects on this product, maximum load 10 kg (22 lb).

Deutsch

ACHTUNG – Empfindlicher Tisch – Nicht auf das Produkt setzen.
 ACHTUNG – Empfindlicher Tisch – Keine schweren Gegenstände auf dieses Produkt legen, maximale Belastung 10 kg (22 lb).

Français

ATTENTION – Table fragile – Ne pas s'asseoir sur ce produit.
 ATTENTION – Table fragile – Ne rien poser de lourd sur ce produit, charge maximum 10 kg (22 lb).

Nederlands

WAARSCHUWING – Kwetsbare tafel – Ga niet op de tafel zitten.
 WAARSCHUWING – Kwetsbare tafel – Plaats geen zware objecten op de tafel, de max. belasting is 10 kg.

Dansk

ADVARSEL – Skrøbeligt bord – Sid ikke på produktet.
 ADVARSEL – Skrøbeligt bord – Placer ikke tunge genstande på produktet, maks. belastning fra 10 kg.

Íslenska

VARÚÐ – Viðkvæmt borð, ekki sitja á vörinni.
 VARÚÐ – Viðkvæmt borð. Ekki leggja þunga hluti á vöruna, hámarksburðarþol 10 kg (22 lb).

Norsk

ADVARSEL – Delikat bord – Skal ikke sittes på.
 ADVARSEL – Delikat bord – Ikke plasser tunge gjenstander på dette produktet, maks vektbelastning 10 kg (22 lb).

Suomi

VAROITUS – Pöytä ei kestä suurta kuormitusta. – Älä istu tuotteen päälle. VAROITUS – Pöytä ei kestä suurta kuormitusta. – Älä aseta painavia esineitä tämän tuotteen päälle. Enimmäiskuormitus 10 kg (22 lb).

Svenska

VARNING – Ömtåligt bord – Sitt inte på produkten.
 VARNING – Ömtåligt bord – Placera inga tunga föremål på denna produkt, maximal belastning 10 kg (22 lb).

Česky

VAROVÁNÍ – Křehký stůl – Nesedějte si na výrobek.
 VAROVÁNÍ – Křehký stůl – Nepokládejte na tento výrobek těžké předměty, maximální zatížení je 10 kg.

Español

ADVERTENCIA – Mesa frágil – No te sientes encima del producto.
 ADVERTENCIA – Mesa frágil – No coloques objetos pesados encima de este producto, carga máxima: 10 kg.

Italiano

AVVERTENZA: tavolo delicato, non sederti sul prodotto.
 AVVERTENZA: tavolo delicato, non posizionare oggetti pesanti sul prodotto, carico massimo 10 kg.

Magyar

FIGYELEM – Sérülékeny asztal – Ne ülj rá!
 FIGYELEM – Sérülékeny asztal – Ne helyezz rá nehéz tárgyakat, maximális terhelés: 10 kg.

Polski

OSTRZEŻENIE – Delikatny stół – nie siadaj na produkcie.
 OSTRZEŻENIE – delikatny stół – nie stawiaj na produkcie ciężkich przedmiotów; maksymalne obciążenie to 10 kg (22 lb).

Eesti

HOIATUS – Õrn laud – Ära istu tootel.
 HOIATUS – Õrn laud – Ära aseta sellele tootele raskeid esemeid, maksimumkoormus on 10 kg.

Latviešu

BRĪDINĀJUMS! Trausls materiāls. Uz šīs preces nedrīkst sēdēt!
 BRĪDINĀJUMS! Trausls materiāls. Nenovietot uz šīs preces smagus objektus. Maksimālā slodze: 10 kg.

Lietuvių

ĮSPĖJIMAS – Lengvai pažeidžiamas stalas – nesėdėkite ant šio gaminio.
 ĮSPĖJIMAS – Lengvai pažeidžiamas stalas – nedėkite sunkių daiktų ant šio gaminio; gamintojo nurodyta didžiausia apkrova 10 kg.

Portugues

AVISO – Mesa delicada – Não sentar no produto.
 AVISO – Mesa delicada – Não colocar objetos pesados sobre este produto. A carga máxima suportada é de 10kg.

Româna

AVERTISMENT – Masă nerezistentă – Nu te așeza.
 AVERTISMENT – Masă nerezistentă – Sarcină max. 10 kg; nu așeza obiecte grele pe acest produs.

Slovensky

UPOZORNENIE – Krehký stôl – Na výrobok si, prosím, nesadajte.
 UPOZORNENIE – Krehký stôl – Na tento výrobok neumiestňujte ťažké predmety, nosnosť je maximálne 10 kg.

Български

ВНИМАНИЕ – Деликатна маса – Не сядайте върху продукта.
 ВНИМАНИЕ – Деликатна маса – Не поставяйте тежки вещи върху продукта, максимално натоварване 10 кг (22 lb).

Hrvatski

UPOZORENJE – Krhak stol – Ne sjedati na proizvod.
 UPOZORENJE – Krhak stol – Ne stavljati teške proizvode na ovaj proizvod; maksimalno opterećenje 10 kg.

Ελληνικά

ΠΡΟΣΟΧΗ – Ευαίσθητο τραπέζι – Μην κάθεστε πάνω στο προϊόν.
 ΠΡΟΣΟΧΗ – Ευαίσθητο τραπέζι – Μην τοποθετείτε βαριά αντικείμενα στο προϊόν, μέγιστο βάρος 10 Kg.

Українська

ЗАСТЕРЕЖЕННЯ – Делікатний стіл – Не сидайте на виріб.
 ЗАСТЕРЕЖЕННЯ – Делікатний стіл – Не розміщуйте важкі предмети на цьому виробі, максимальне навантаження: 10 кг.

Srpski

UPOZORENJE – Osetljiv sto – Nemoj sedati na proizvod
 UPOZORENJE – Osetljiv sto – Nemoj stavljati teške predmete na ovaj proizvod, maksimalna nosivost 10 kg.

**Slovenščina**

POZOR – Občutljiva miza – Izdelek ni primeren za sedenje.
 POZOR – Občutljiva miza – Na ta izdelek ne polagaj težkih predmetov. Največja dovoljena obremenitev: 10 kg.

Türkçe

UYARI - Hassas masa - Ürünün üzerine oturmuyunuz.

UYARI - Hassas masa - Bu ürünün üzerine ağır nesnelere yerleştirmeyiniz, maksimum yük 10 kg (22 lb).

中文

警告 - 易碎桌子 - 请勿坐在产品上。

警告 - 易碎桌子 - 请勿将重物放置在本产品上，最大承重为10公斤 (22磅)。

繁中

警告 - 容易損壞 - 切勿坐在桌上

警告 - 容易損壞 - 請勿在產品上放置重物，最高可承重10公斤(22磅)

한국어

주의 - 제품에 앉으면 테이블이 파손될 수 있으니 앉으면 안 됩니다.

주의 - 최대 하중은 10kg(22lb)이므로, 제품에 무거운 물건을 올리면 테이블이 파손될 수 있습니다.

日本語

警告 - 繊細なテーブル - 上に座らないでください。

警告 - 繊細なテーブル - 上に重いものを置かないでください。最大荷重は10kgです。

Bahasa Indonesia

PERINGATAN - Meja halus - Jangan duduk di atas produk.

PERINGATAN - Meja halus - Jangan letakkan benda berat di atas produk ini, beban maksimum 10 kg (22 lb).

Bahasa Malaysia

AMARAN – Meja tidak kukuh - Jangan duduk di atas produk ini.

AMARAN – Meja tidak kukuh - Jangan letakkan objek berat di atas produk ini, beban maksimum pengilang 10 kg (22 lb).

عربي

تحذير - طاولة حساسة - لا تجلسي على المنتج.
 تحذير - طاولة حساسة - لا تضعي أشياء ثقيلة على هذا المنتج.
 الحمولة القصوى 10 كجم (22 رطلا).

ไทย

คำเตือน: โต๊ะไม่เหมาะกับการรับน้ำหนักมาก ห้ามนั่งบนสินค้านี้
 คำเตือน - โต๊ะไม่เหมาะกับการรับน้ำหนักมาก - ห้ามวางสิ่งของหนักลงบนสินค้านี้ น้ำหนักสูงสุดที่รองรับได้ 10 กก. (22 ปอนด์)

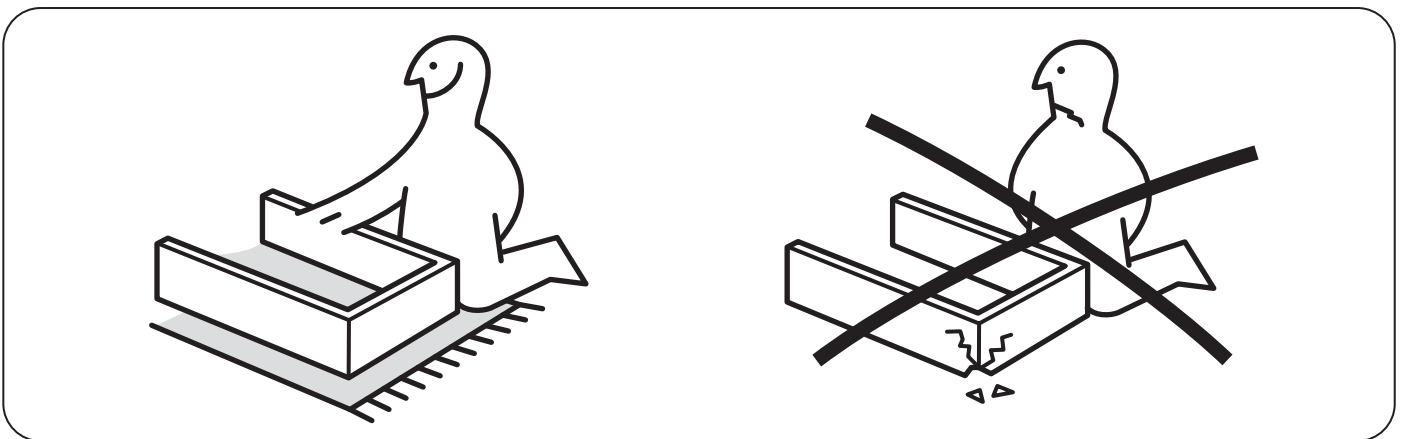
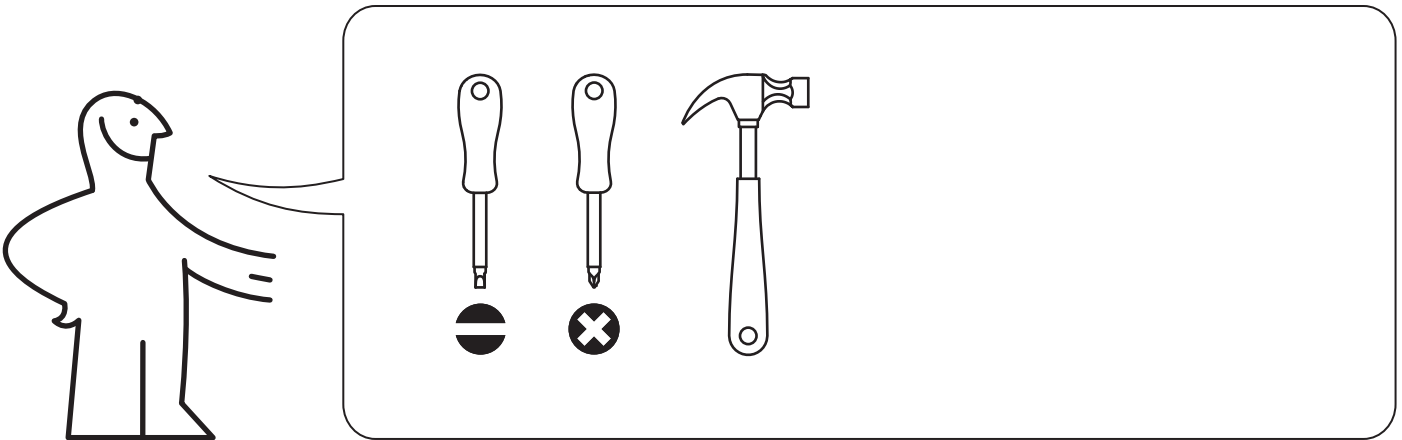

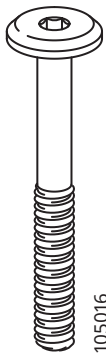
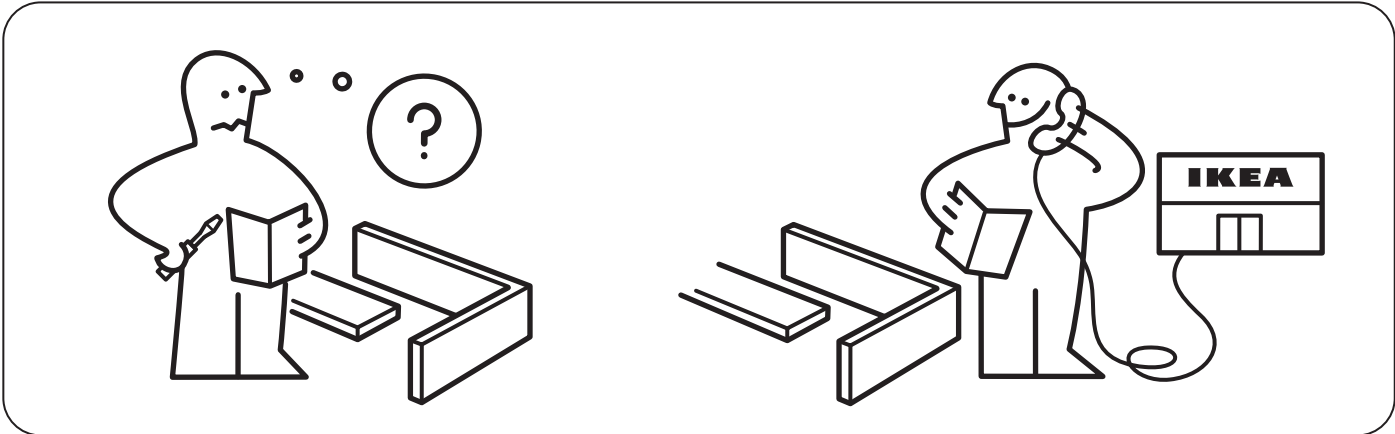

105016
16x

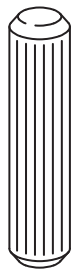

101359
8x

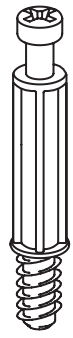

118331
8x

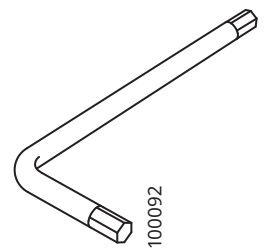

100092
1x

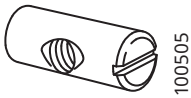

100505
8x



110630
8x



110788
2x

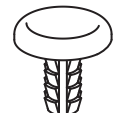

112357
8x

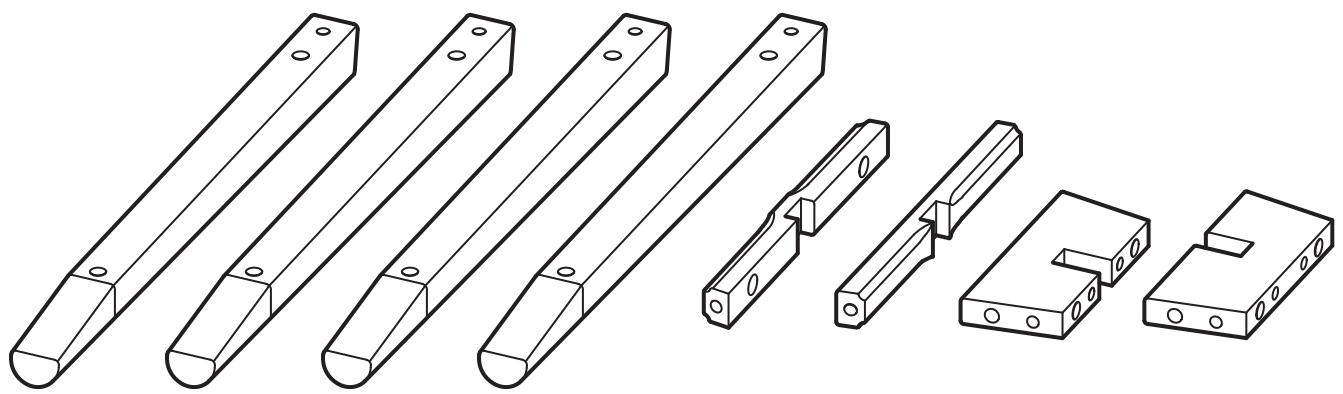
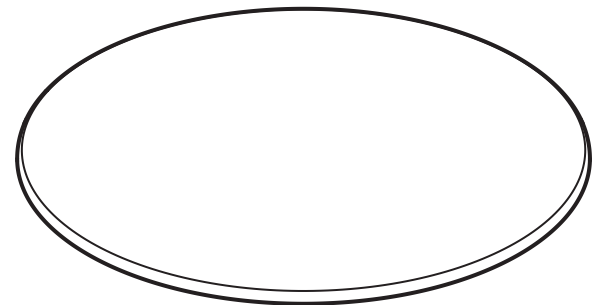
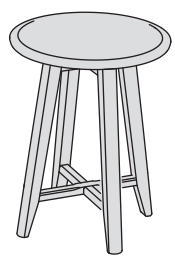
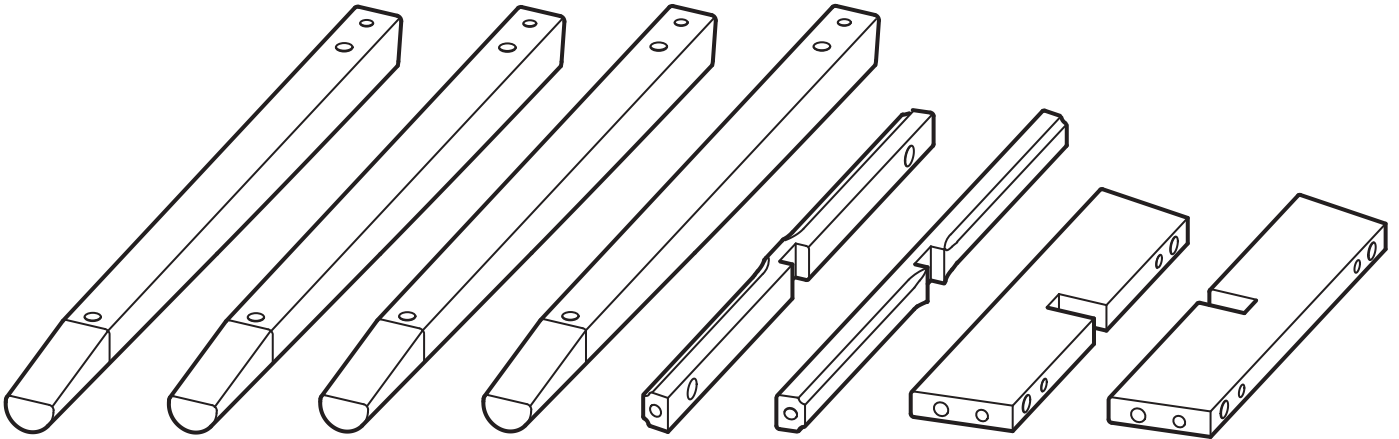
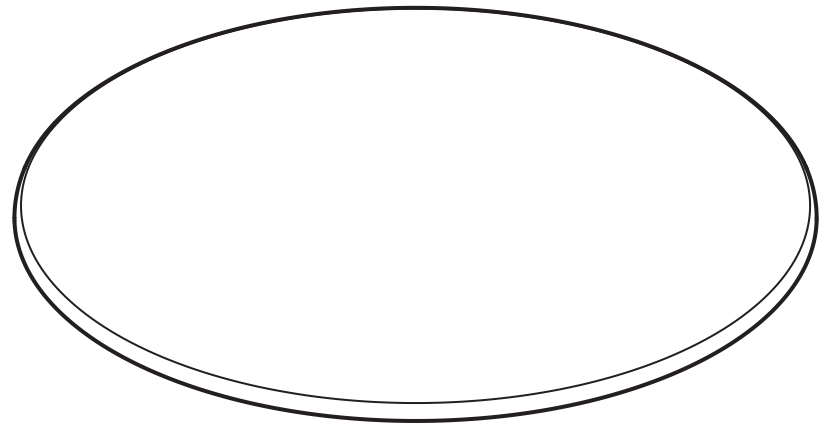
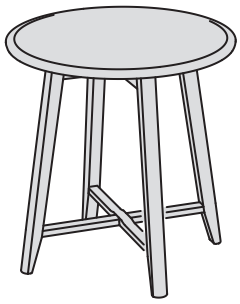

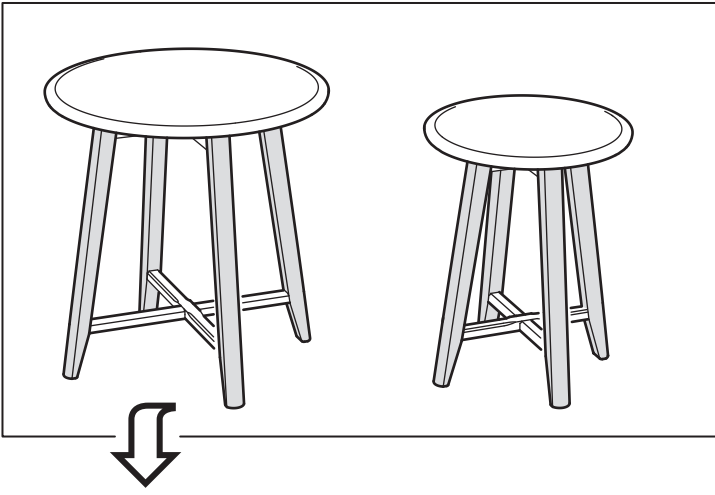

1

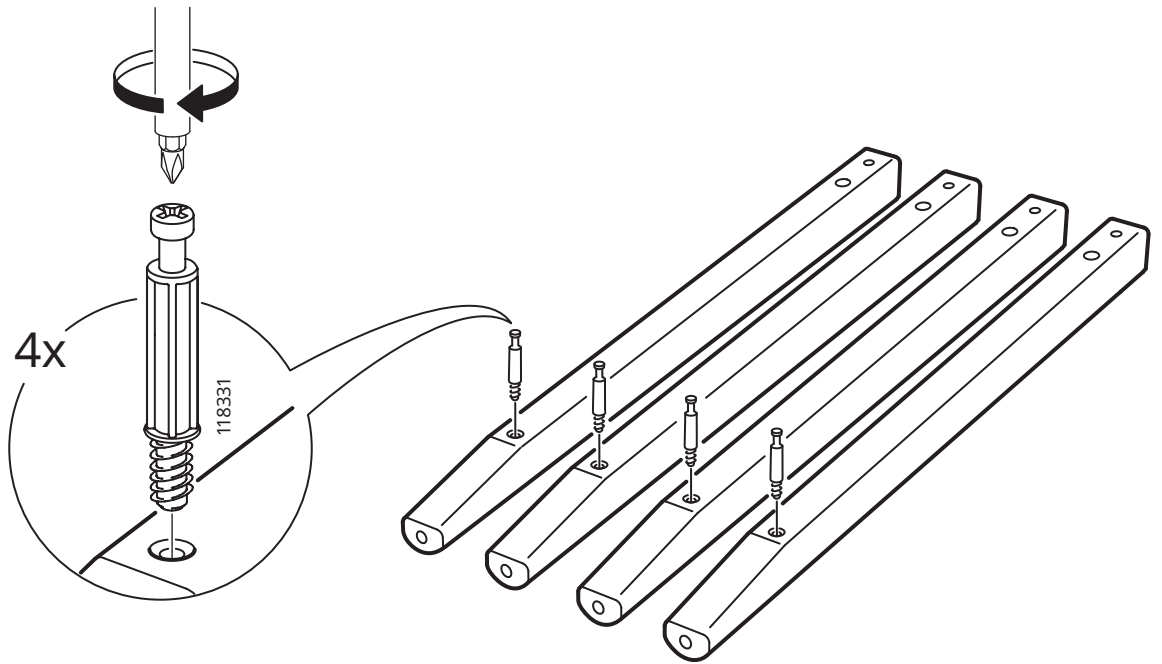

2

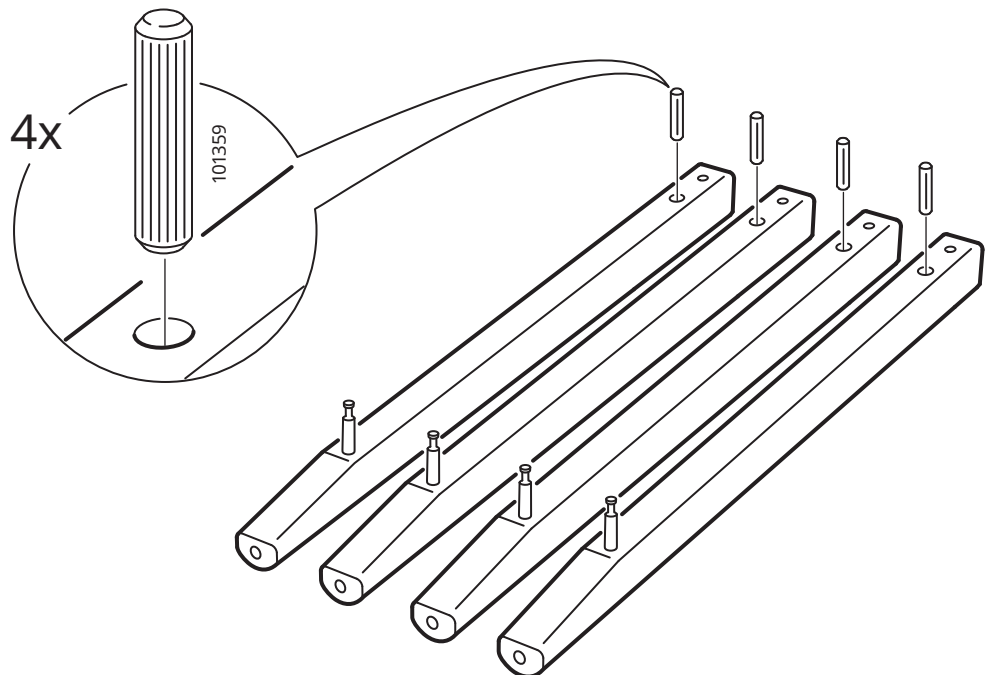

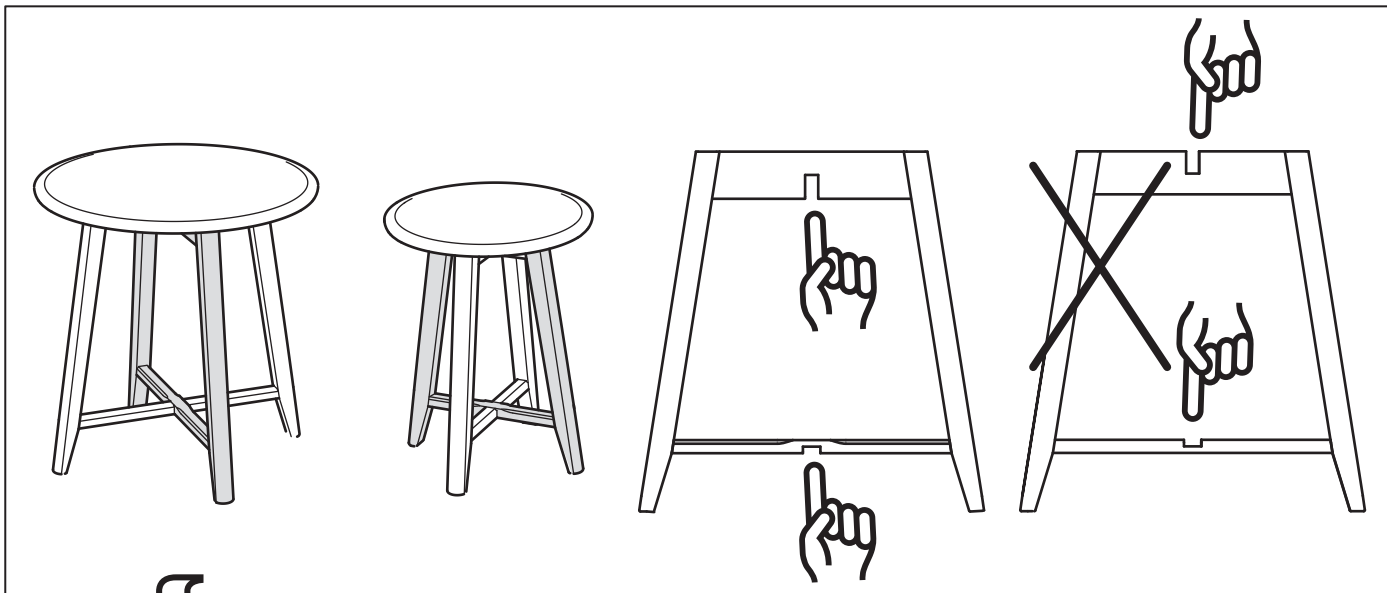

3

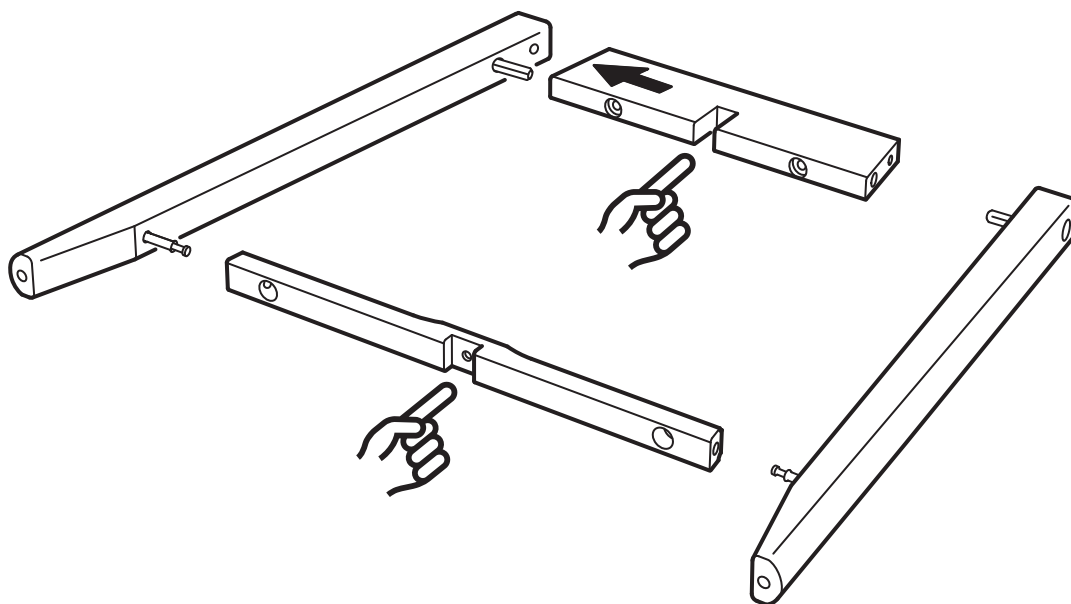

4

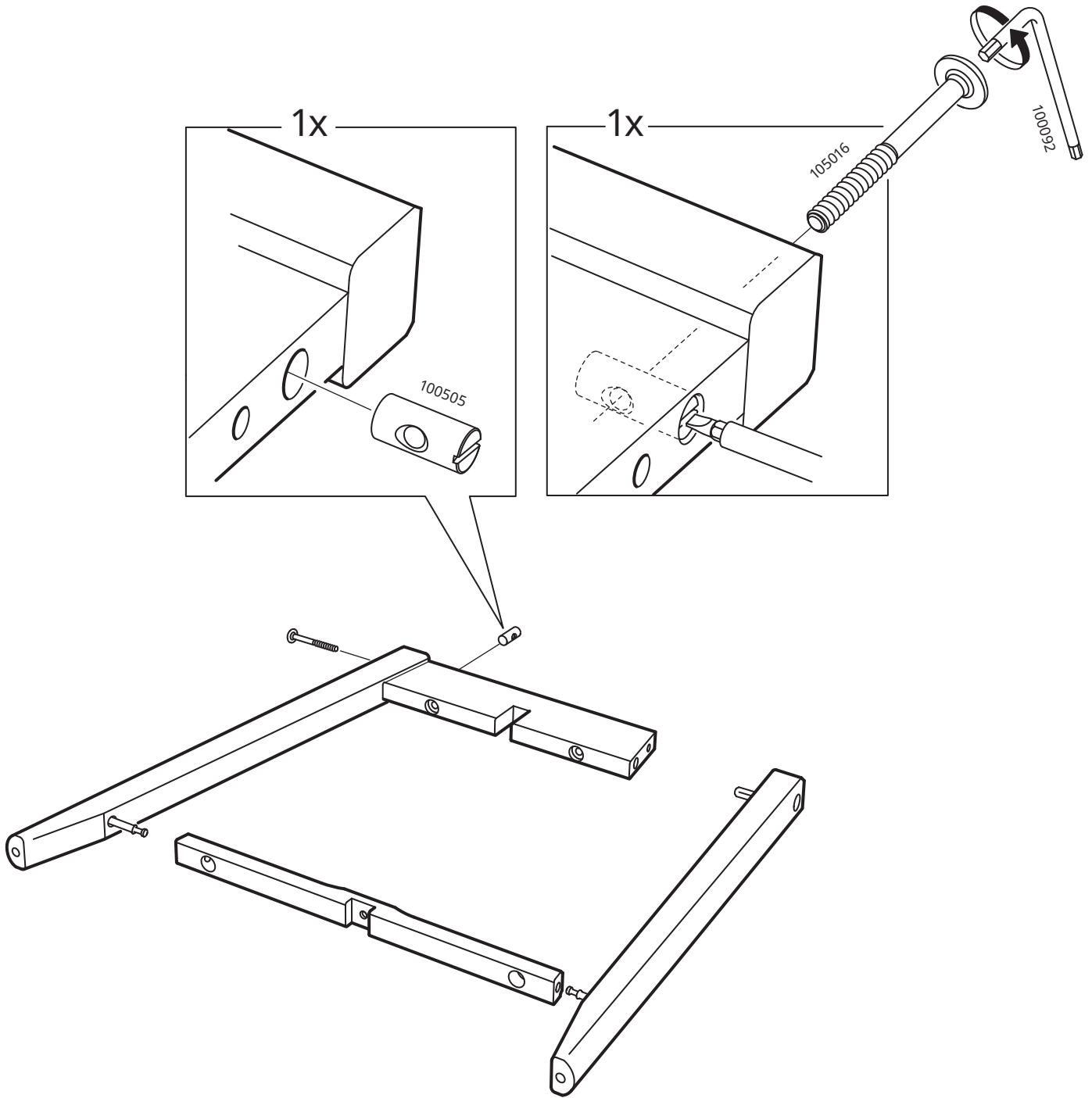

5

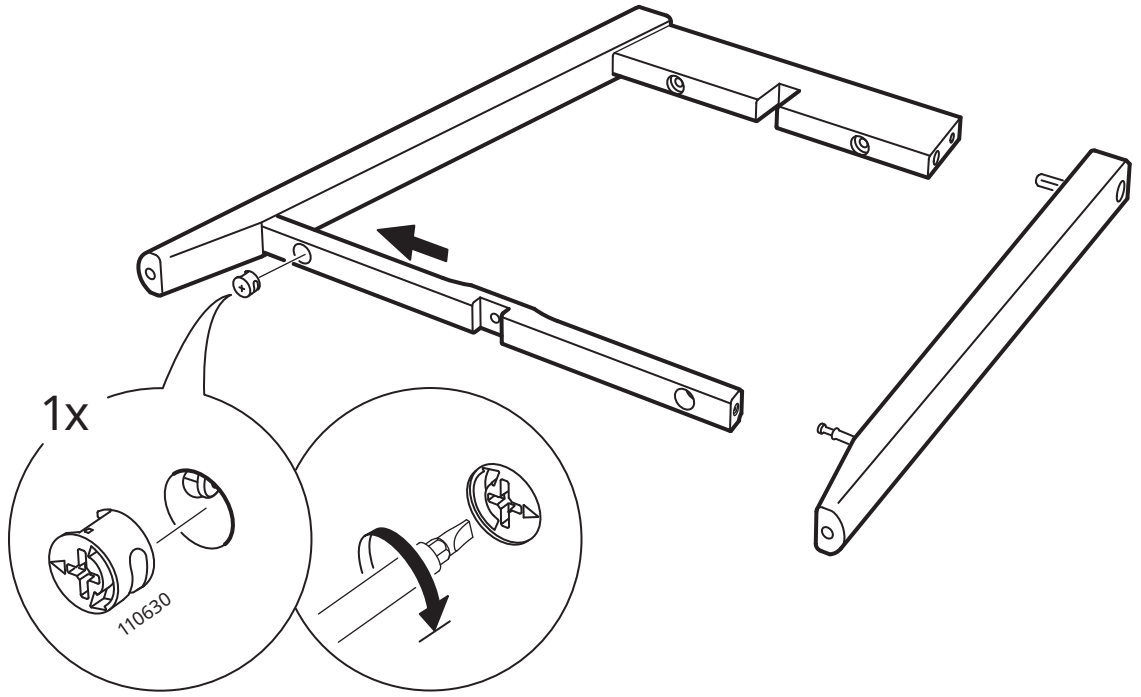

6

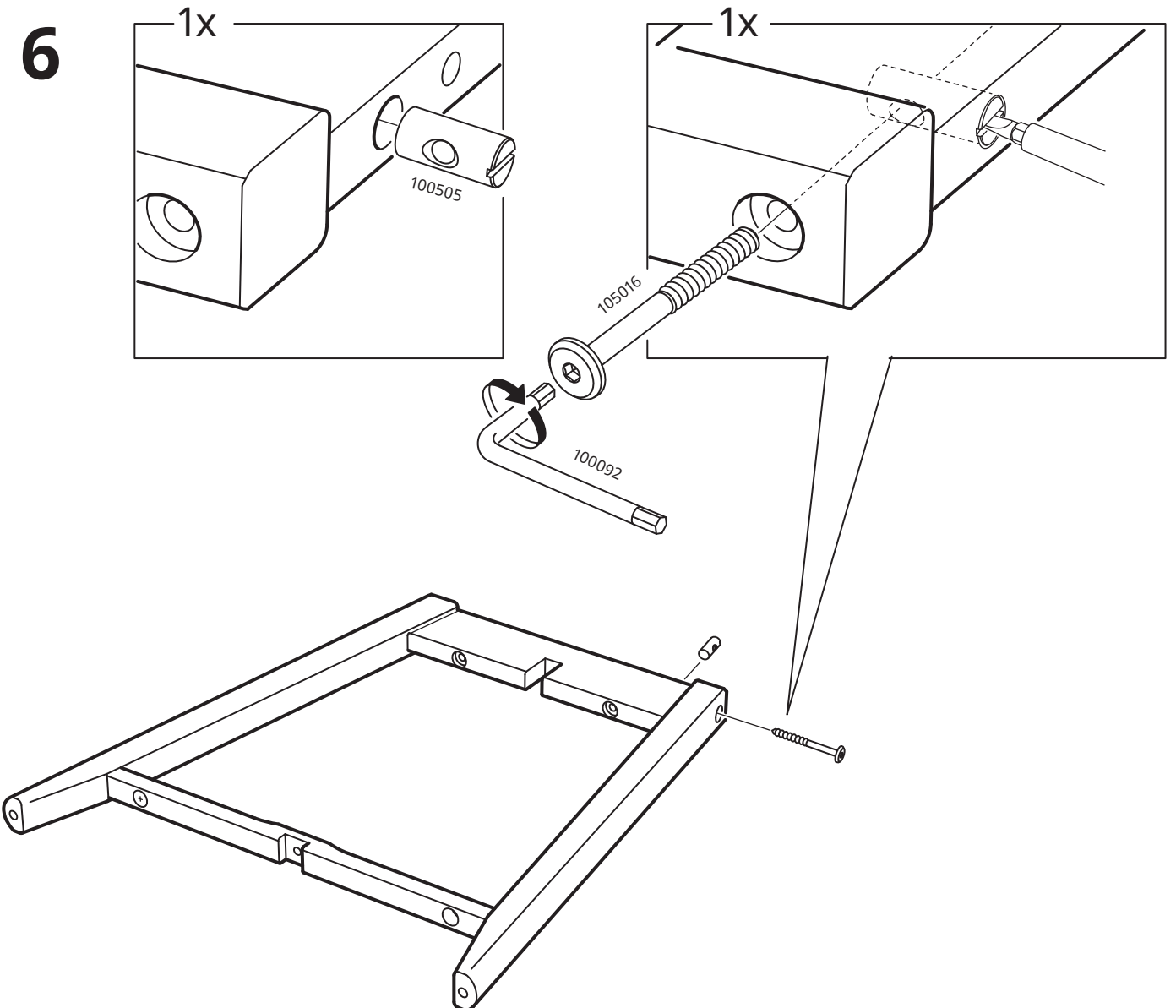

7

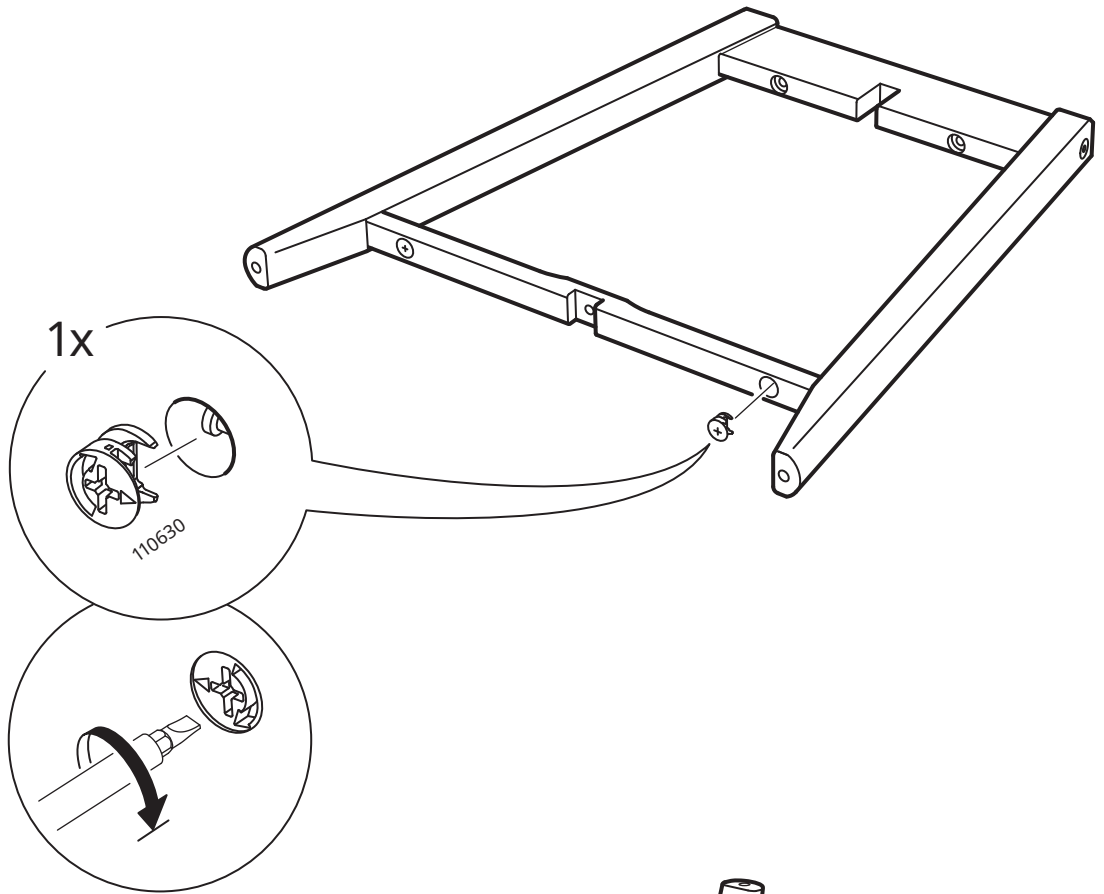

8

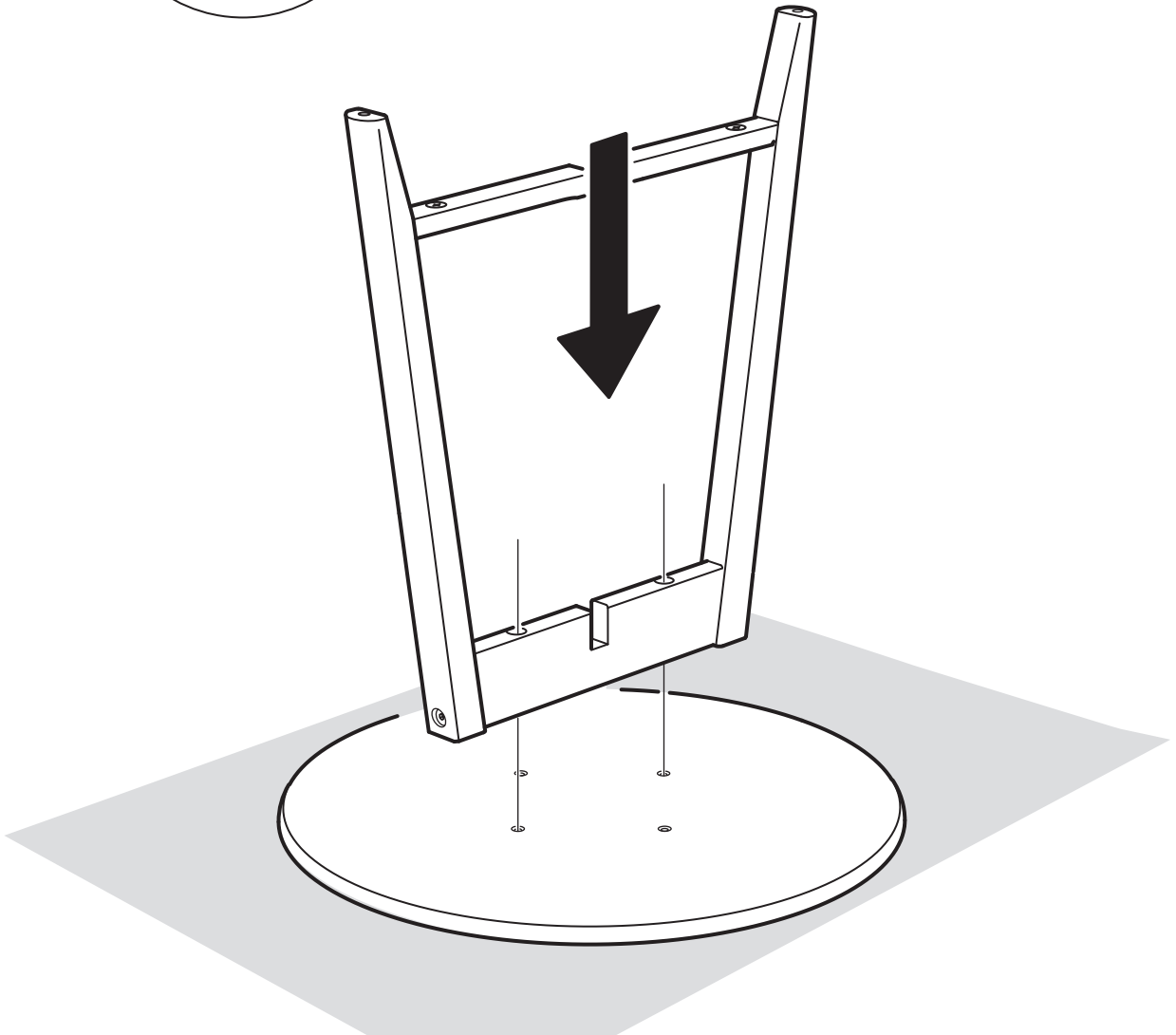

9

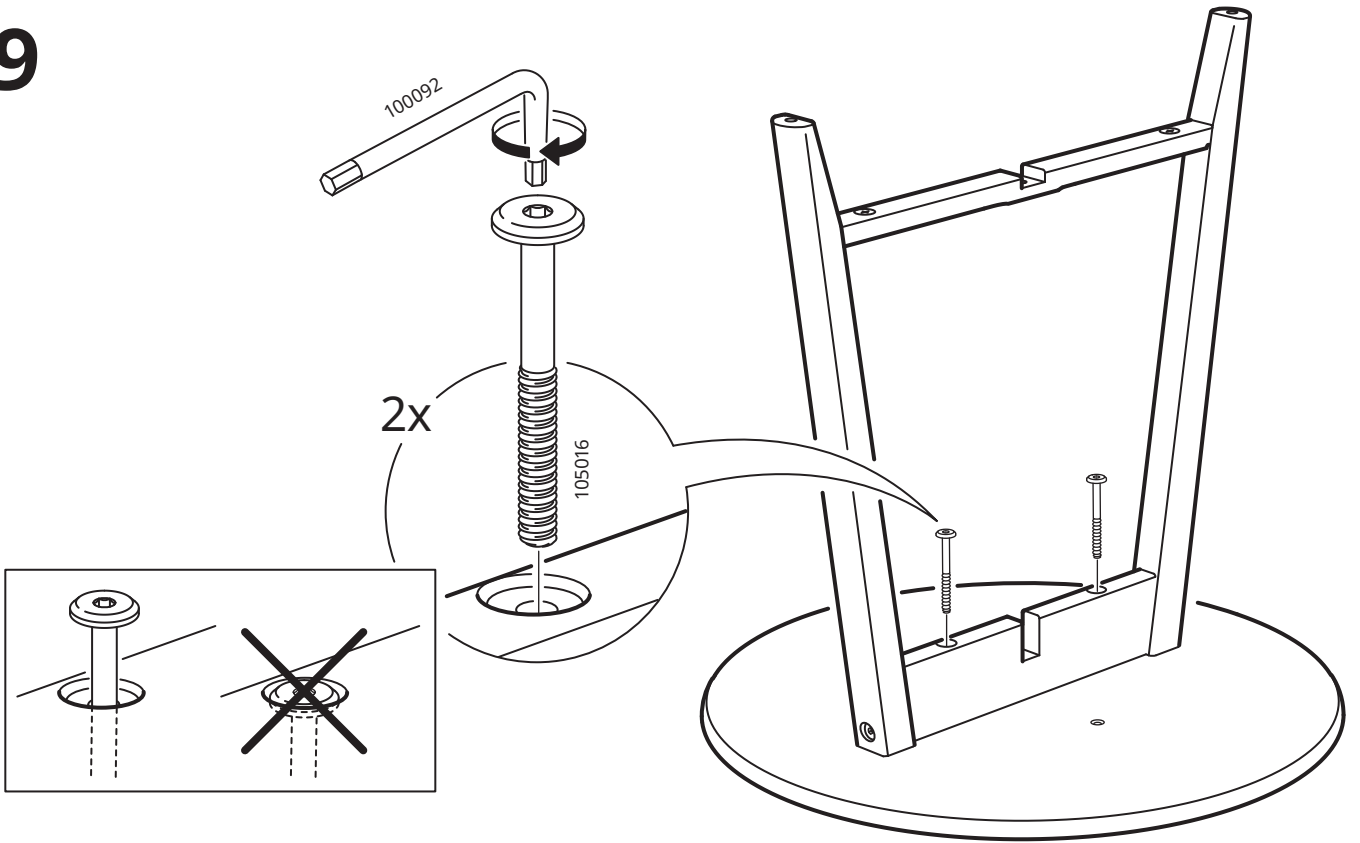

10

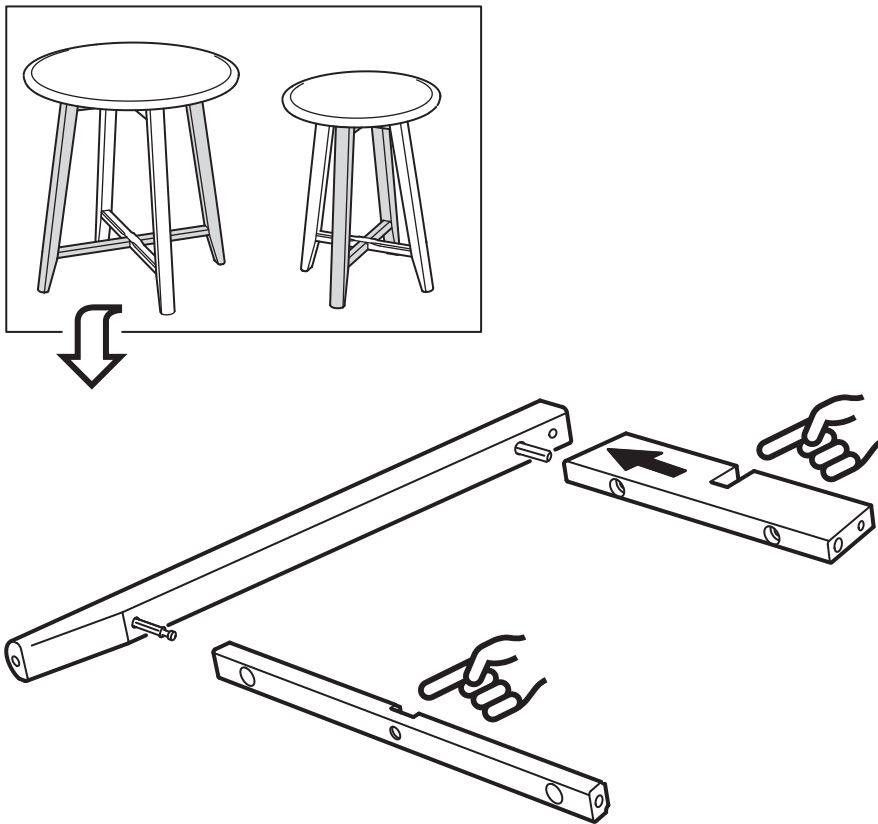

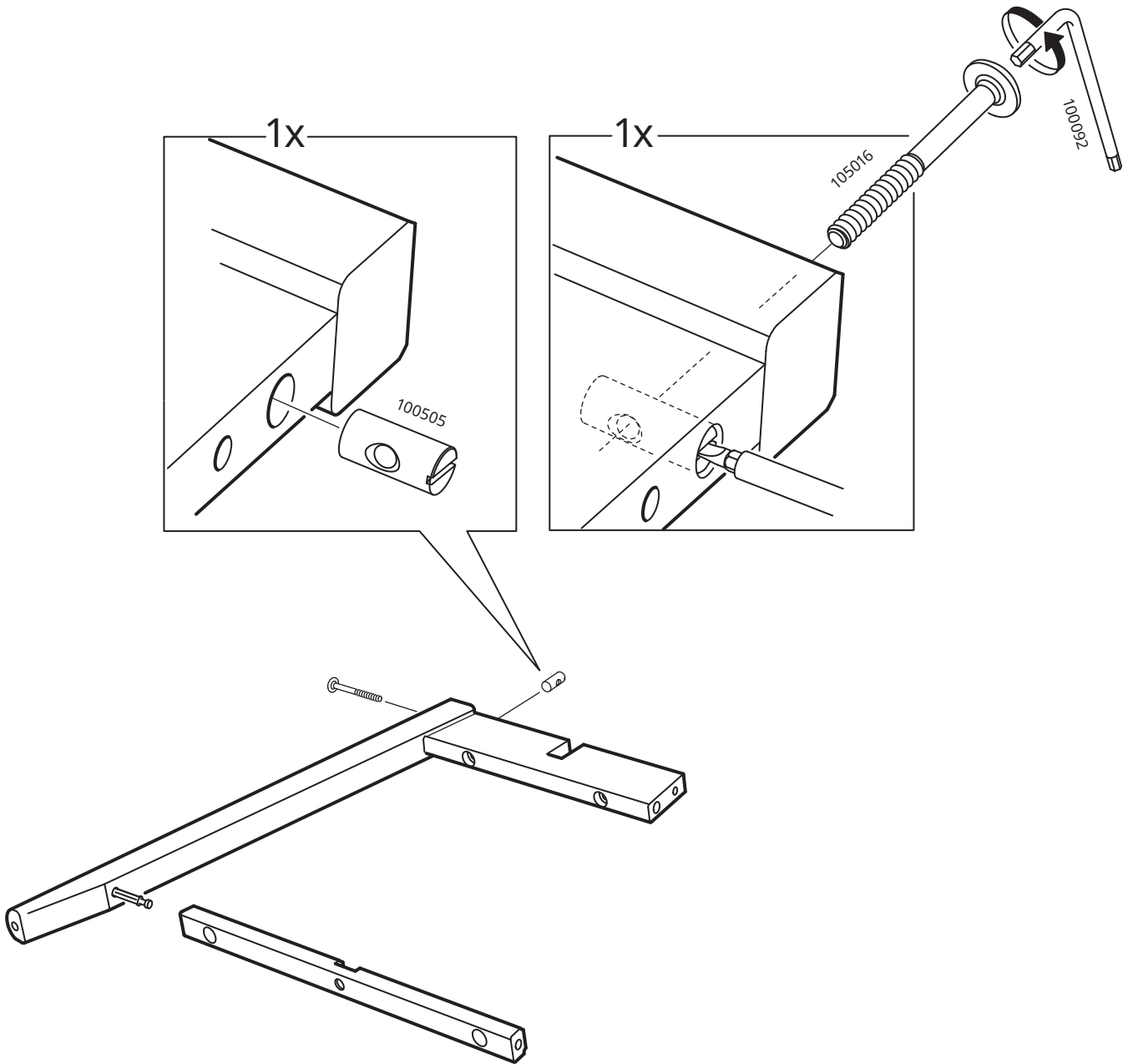

12

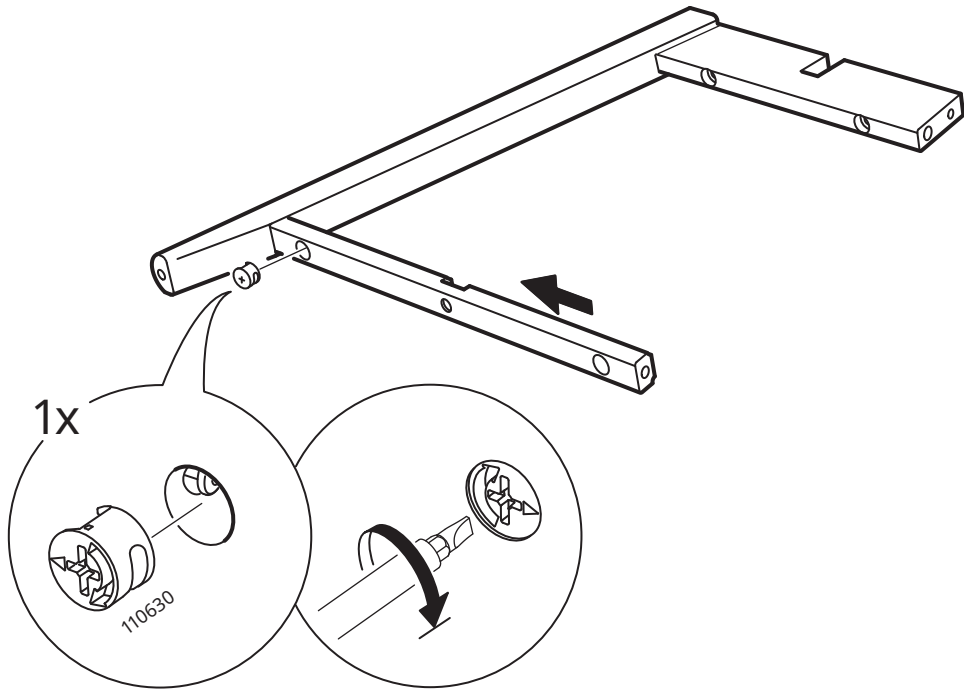

13

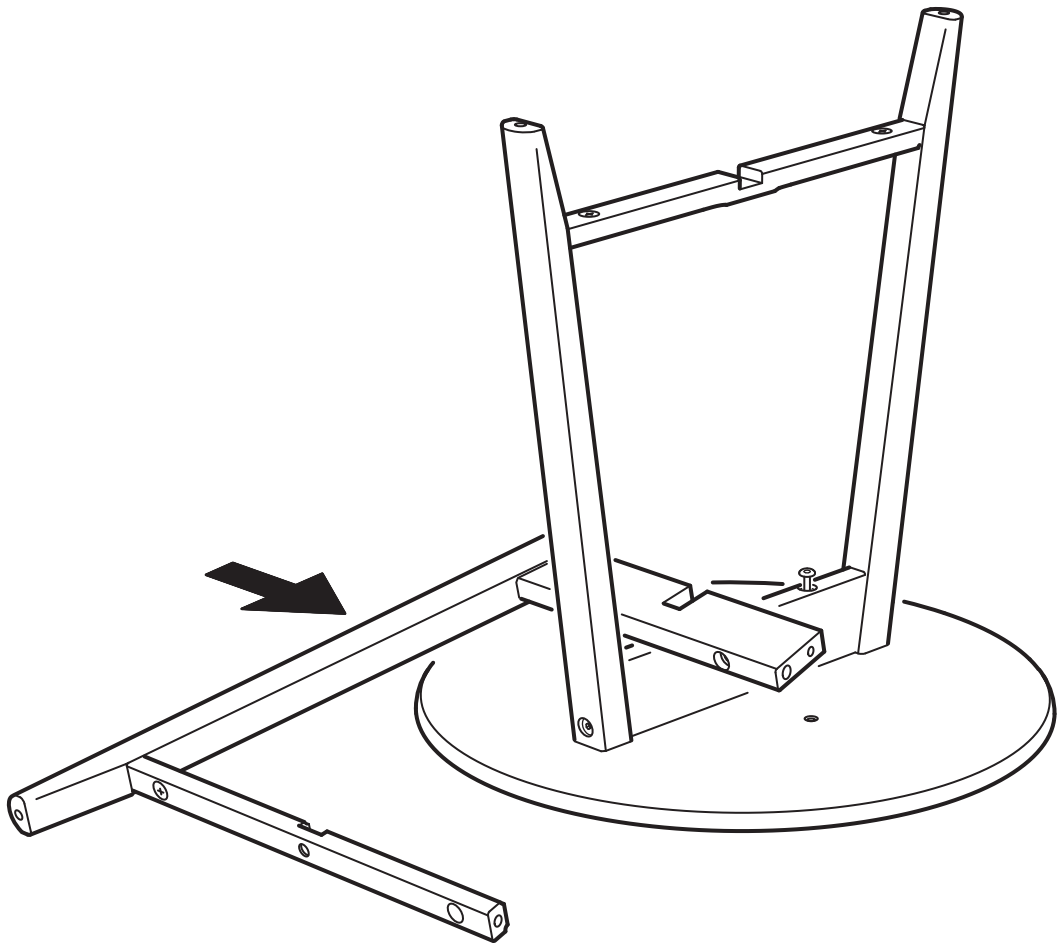

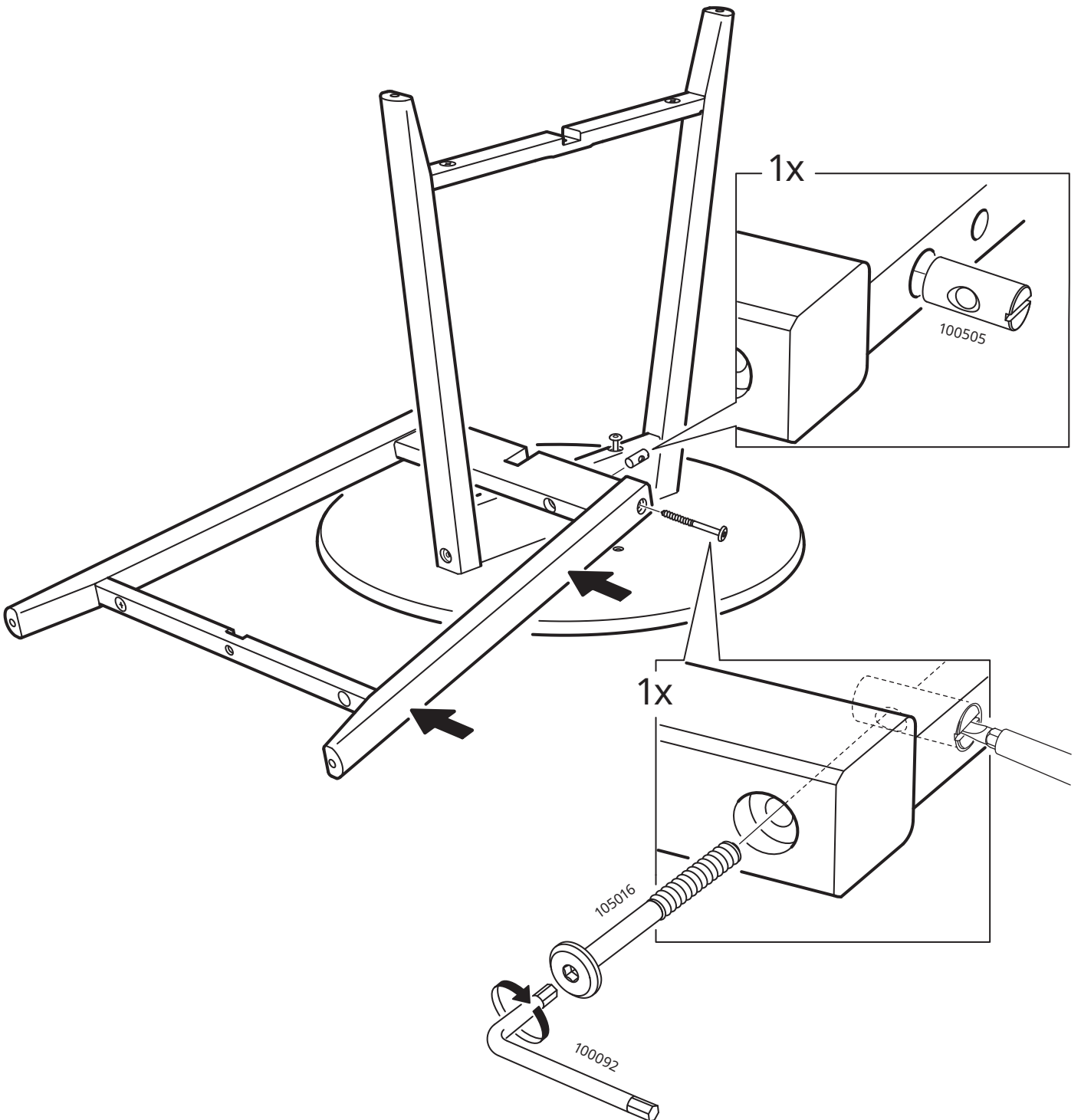

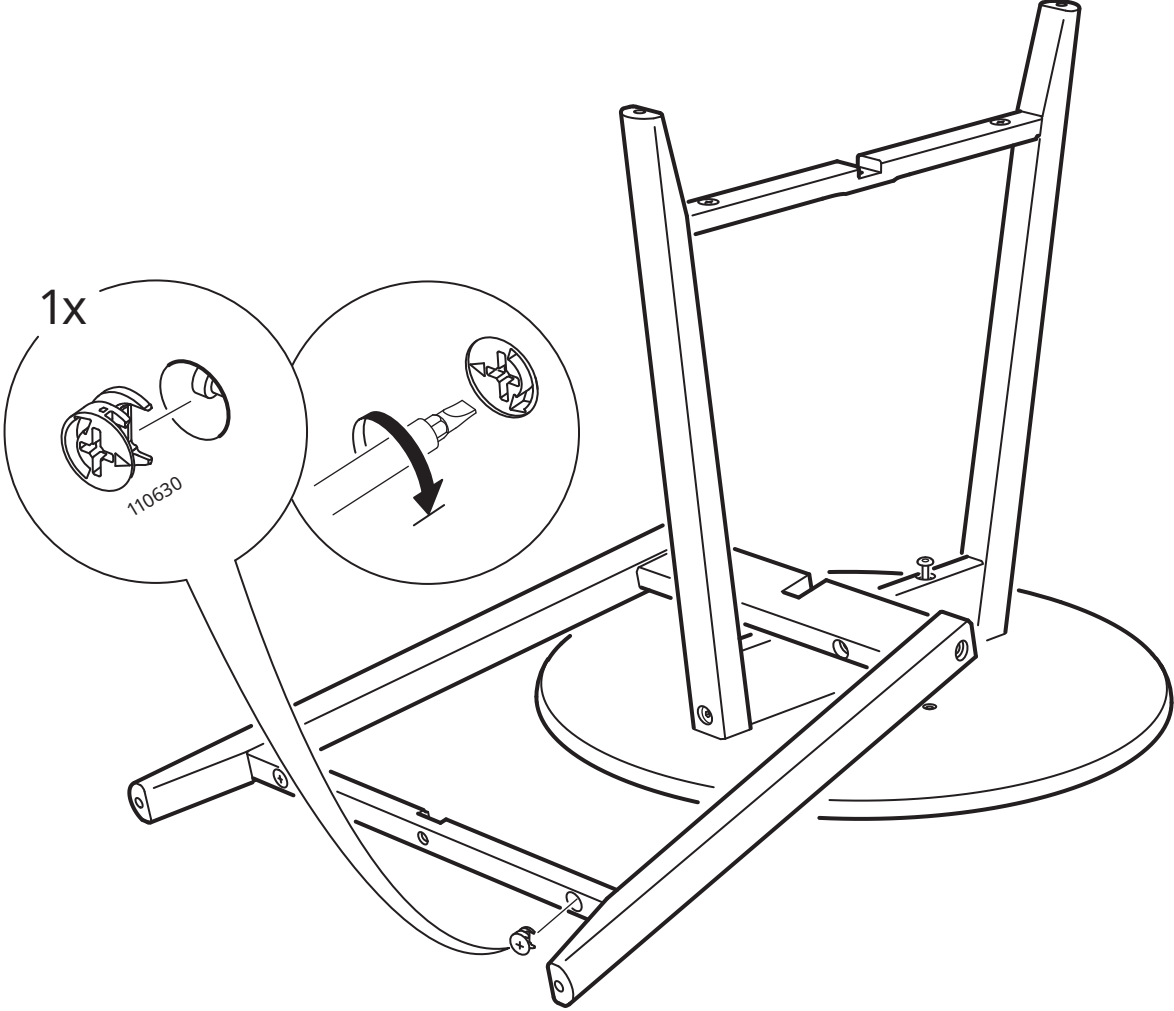

16

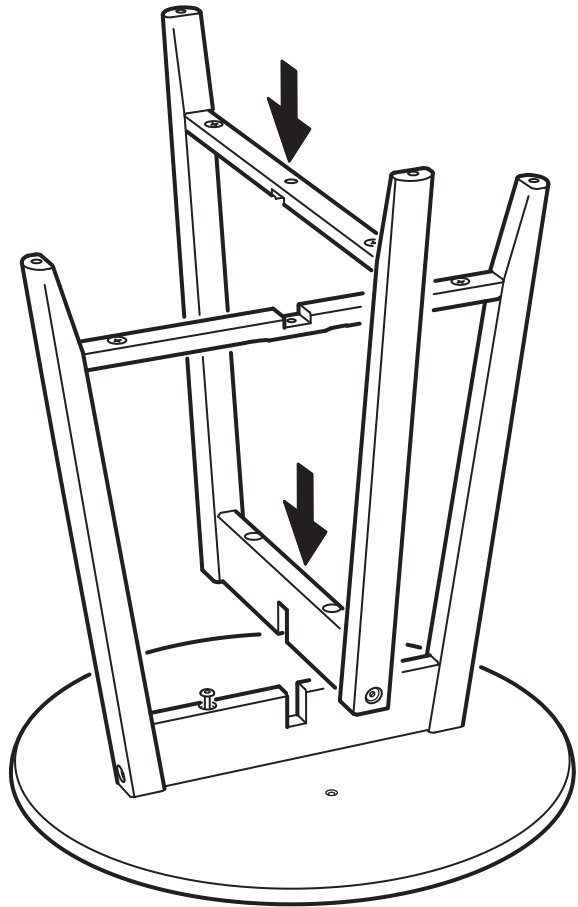
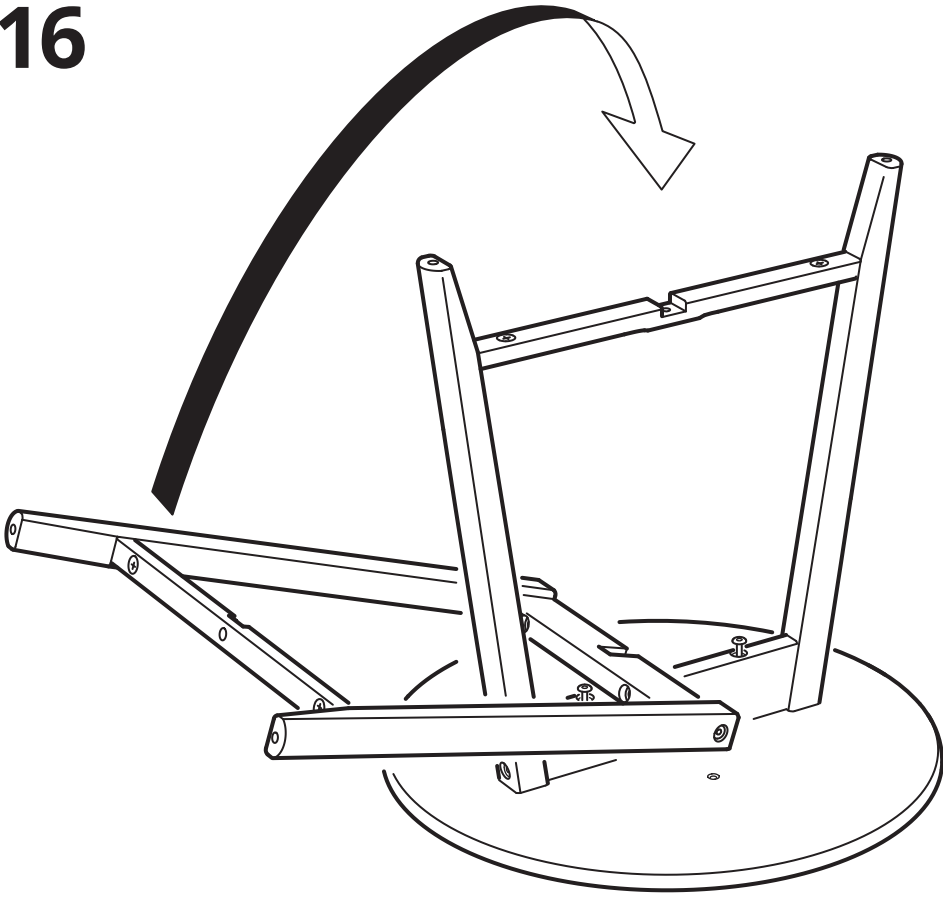

17

